

CRS Services

FAA Certified Repair Station

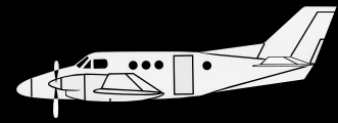



The following pages reflect only a sample of the many repair services offered by AvFab. Please contact us at sales@avfab.com for a free quote and current lead time estimate for your particular aircraft service needs.

FAA-Parts Manufacturing Approval Facility - #PQ3012CE
FAA-Certified Repair Station - #GVRR304K

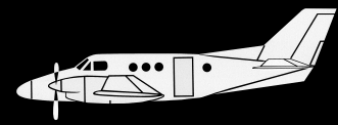

Seat Recline Cylinders



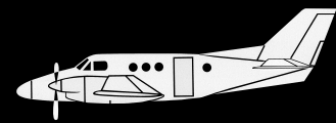

Seat Recline Cylinders

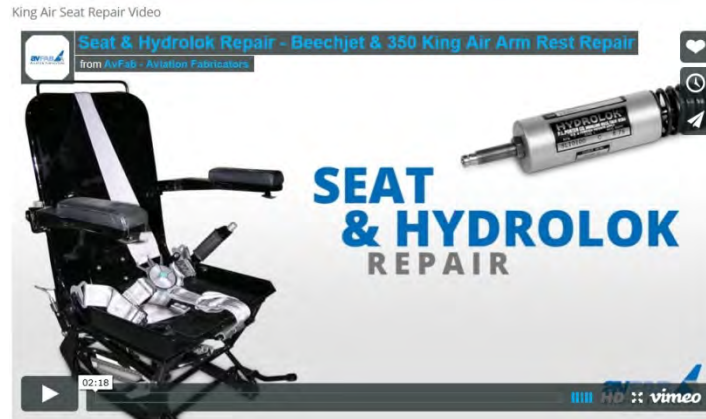

AvFab pioneered the quick-turn around overhaul of PL Porter Hydrolok, Enidine UltraLoc, Roton, and other seat recline cylinders to "like new" condition at the fraction of the cost of a new replacement cylinder with the same warranty as new! To view a video of our CRS Seat Recline Cylinder Repair go to <https://vimeo.com/135266678>

Manufacturers: PL Porter, Enidine, Roton, others

Approval: FAA 8130-3
EASA 8130-3 Dual Release

Lead Time: Aviation Fabricators will repair and/or overhaul your actuators within 2 working days after receipt of unit. Same day service is normally available if you need faster turn time.

Service: Repair and/or overhaul – Services are performed by certified Airframe mechanics and Repairmen who have learned many techniques that are unique to the unit types. Exchange units are available for most models.

Warranty: Aviation Fabricators warrants each unit for one year from date of overhaul, provided it has not been abused, altered or subjected to abnormal use.

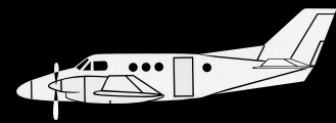

Externally Serviced Toilets



- Part Number:** DCA250005-X Series w/ Weber Toilet, Monogram 15300, 4620-15900, 12300, 15550, Clean Flush Toilets
- Aircraft:** Hawker, Dassault, Lear, others
- Features:** Customer toilet will be overhauled, including drain valve, tank leaks repaired, tank resealed, on Weber units will be modified with new pump/motor assembly installed.
- Options:** Rebuilt pump/motor assembly may be available as an option.
- Weber Details:** Converts Weber toilets with pump/motor assembly that is no longer available to new style Monogram pump/motor. This converts the Weber toilet to a more reliable system with parts and repairs readily available.
- Limitations:** None
- Approval Type:** FAA / AvFab Repair Specification GVPS-1163
- Lead time:** Normally 5 to 10 working days to complete the repair/modification on customer toilet.
- Warranty:** One year warranty.

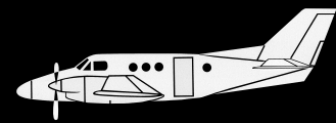

Monogram Flushing Units

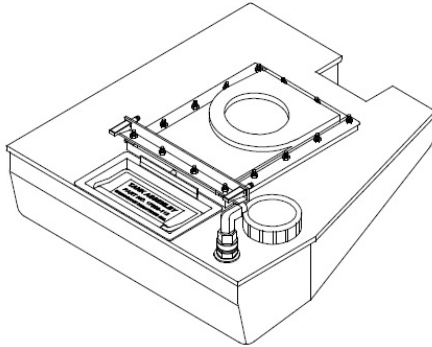
**Part Numbers:**

17000-XXX series tanks
17010-XXX series tanks
17020-XXX series tanks

Aircraft:

Various

Description:

Aviation Fabricators is FAA approved to repair and overhaul all series Monogram tank assemblies. Our repair processes will return the tanks to their original operating specifications at a greatly reduced cost when comparing to a new replacement part. Lead time is greatly reduced when utilizing our repair services, as opposed to buying new. We have developed, specifically for the Monogram tanks, a repair process for re-sealing and repairing leaking tanks, which returns them to like new condition. All repairs are done in our facility by experienced technicians, who take great pride and care in the work they do. We strive to ensure that our work exceeds your expectations, and the repaired unit will give you the same level of service you would expect from a new one.

Options:

Exchange units are available for many tanks.

Lead Time:

Normal lead time to overhaul these units is 5 to 7 days. However, fluctuations in demand can cause this to be longer. Please contact us for an accurate estimate.

Approval:

FAA 8130-3
EASA 8130-3 Dual Release

Warranty:

Aviation Fabricators warrants each unit for one year from date of overhaul, provided it has not been abused, altered, or subjected to abnormal use.

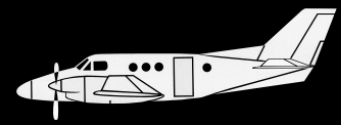

Coffee Units & Heated Liquid Containers



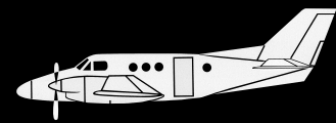

Coffee Units & Heated Liquid Containers

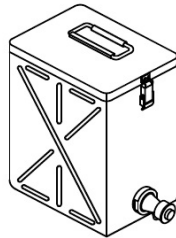

ELECTROTHERM

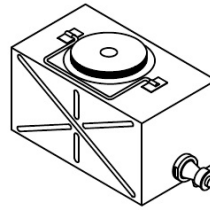

PREPCO

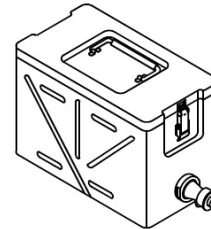

MAPCO

Manufacturer:

Adams Rite Aerospace: Models Series: AR9061, AR9062, & AR9063
B/E Aerospace, FL Aerospace, Grimes, Mansfield A/C Products, Mapco – Model Series: 180, 297, 306, 610, 764, 1158 & 1388
Bomhoff – Model Series: M3113093
Creative Interiors – Model Series: 660486-
Custom Aircraft Conversions – Model Series: BDD5.0020-2
Electrotherm – Model Series: EL-M-100/28C, EL-M-100/28Ex, EL-M-150/28C
Global Engineering – Model Series: 130, & 200
Hawker Beechcraft – Model Series: 138-530942
Hiller – Model Series: H45PWC-02001-1, H45SSWC-02001, HLWC03205, & HLWC-03504
Maynard – Model Series: A1-AW-007-15, 99R489, & 138-530489
Midland Ross: 1060, 1095, & 1097 Series
Midwest Aircraft Products – Model Series: 1187, 1189, 1247, 1248, 1251, 1268, & 1290
Prepco – Model Series: BDD5.0020-3, 8390, 12614, 13222, 80037, 80181, 80605, 80829, 81246, 81303, 81314, 81315, 81319, 81328, 81434, 81355, 81366, 81377, 81391, 6607024- Series, 017 series, F50 series.

Spigots: Spigot Re-Seal Kits:
 All Models P/N 25-0446K (Prepco)
 P/N 25-0449K (Mapco)

Approval: FAA 8130-3
 EASA 8130-3 Dual Release

Lead Time: Aviation Fabricators will repair or overhaul your heated liquid container within 5 working days after receipt of unit. AOG service is available if you need faster turn time.

Service: Repair and/or Overhaul – Services are performed by certified Airframe mechanics and Repairmen who have learned many techniques that are unique to the unit types. Exchange units are available for most models.

Warranty: Aviation Fabricators warrants each unit for one year from date of overhaul, provided it has not been abused or subjected to abnormal use. In the case of a repaired unit, that was not overhauled, the warranty will only cover the parts replaced by Aviation Fabricators when repaired.

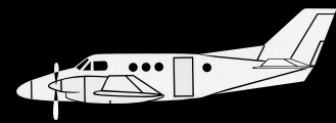

Cabinet Shop Services

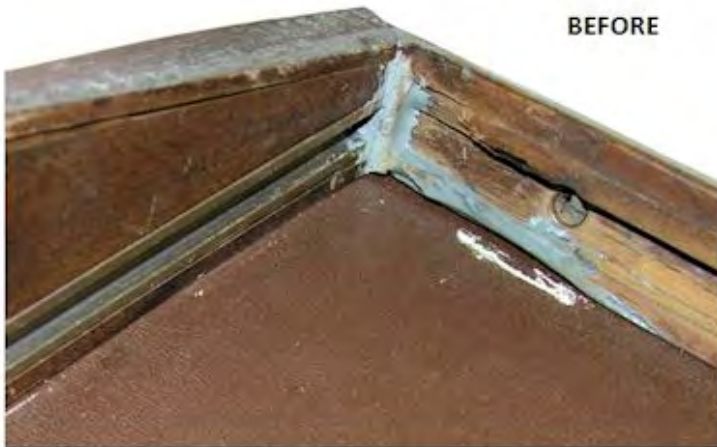

BEFORE



AFTER



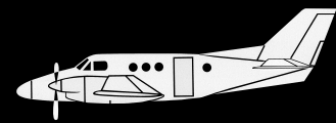

Cabinet Shop Services

AvFab's Cabinet Technicians are artisans in their own right, skillful in both modern composite materials and in traditional solid wood and wood veneers. Our in-house facility allows us to provide high quality custom fabrication, modification, repairing and refinishing for all types of interior cabinetry and furniture.

Here is a partial list of interior items our technicians can work with:

- Bulkheads & Partitions
- Drawers
- Galleys
- Cabinets
- Divider Doors
- Tables
- Toilet Enclosures
- Close Out Panels
- Jepp Chart / Magazine Racks



Approval: FAA 8130-3
EASA 8130-3 Dual Release

Lead Time: Contact AvFab for an accurate time estimate for repairing your cabinets and interior furniture.

Service: Repair and/or overhaul

Warranty: Aviation Fabricators warrants each unit for one year from date of overhaul, provided it has not been abused, altered or subjected to abnormal use.

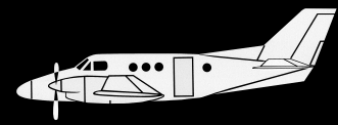

Seat Repair Services



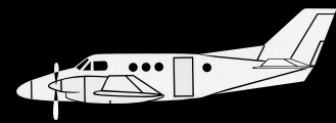

Seat Repair Services

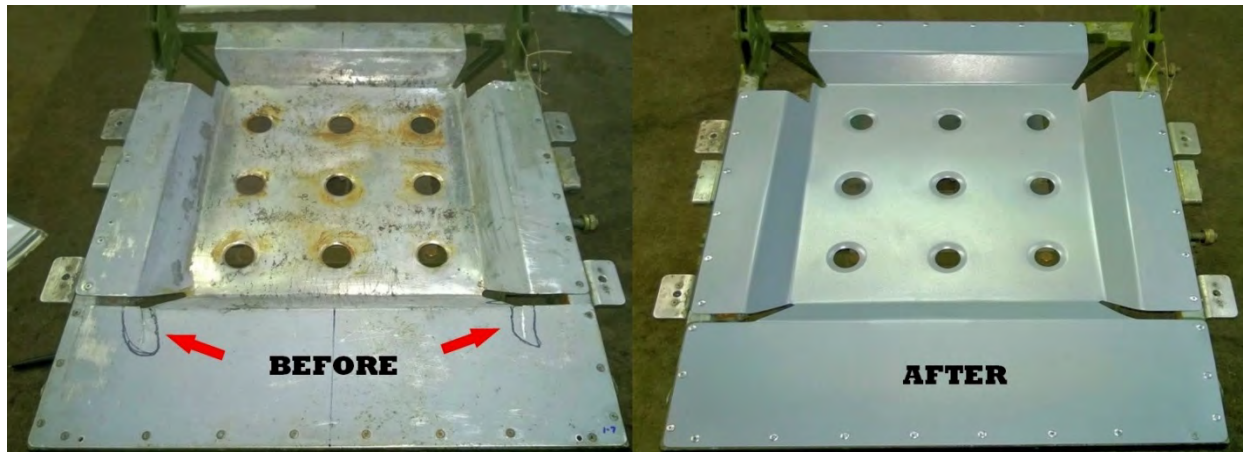

AvFab has developed comprehensive repair processes to address broken or weakened seat frames and other common wear areas in both crew and passenger seating. After a thorough cleaning and inspection of components, the customer will be informed if any additional damage is found before proceeding. All repairs are engineered and certified in accordance within FAA specifications. Seat frames are primed and returned for re-installation with appropriate documentation.

All repairs are done at the AvFab facility, and great care is taken to preserve the chair foam and covering so they can be reinstalled after the repairs have been accomplished, if necessary.

AvFab can service and repair seat frames (both welded and brazed), arm rests, seat pans, recline actuators, and component hardware replacement.

Approval: FAA CRS

Lead Time: Contact AvFab for an accurate time estimate for repairing your crew and passenger seats.

Service: Upon receipt of seats a thorough inspection is performed. Repair and/or Overhaul Services are performed by certified airframe mechanics and repairmen who have learned many techniques that are unique to the unit types.

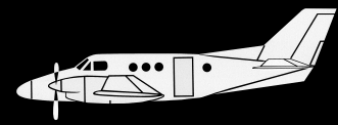

Citation Seat Repair



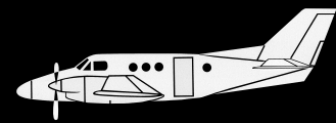

Citation Seat Repair

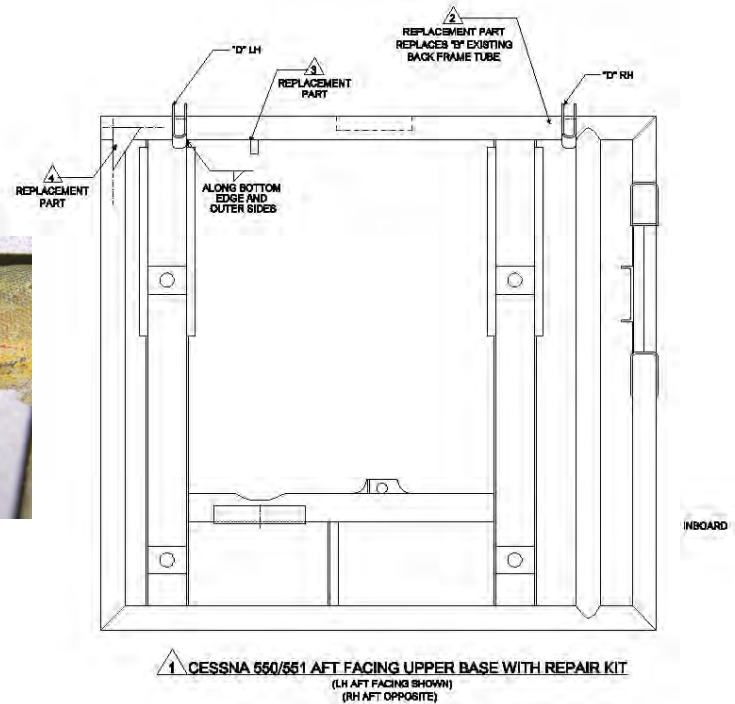

Part Number:

- 42-0310K 500 & 501 Forward facing seat
- 42-0311K 500 & 501 AFT facing seat
- 42-0312K 550 & 551 Forward facing seat
- 42-0313K 550 & 551 AFT facing seat

Aircraft: Citation 500, 501, 550, & 551

Features: Many of the original seat frames are cracked or broken and this STC was designed to repair these bases in a manner that would improve your safety and durability. It saves money and improves the base at the same time.

Options: Exchange seat bases are generally available

Details: The AvFab STC repair actually upgrades the seat structure to "stronger than new". Many of the stress points of the seat frame are replaced with stronger material, during repair

Limitations: None

Installation: Re-installs the same as the original base

Approval: STC & PMA, eliminating the need for the field approval.
 FAA ST0402WI, ST0403WI
 Canada C-09-0897

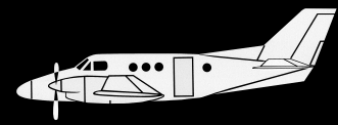

Cessna Seat Bottom Repair

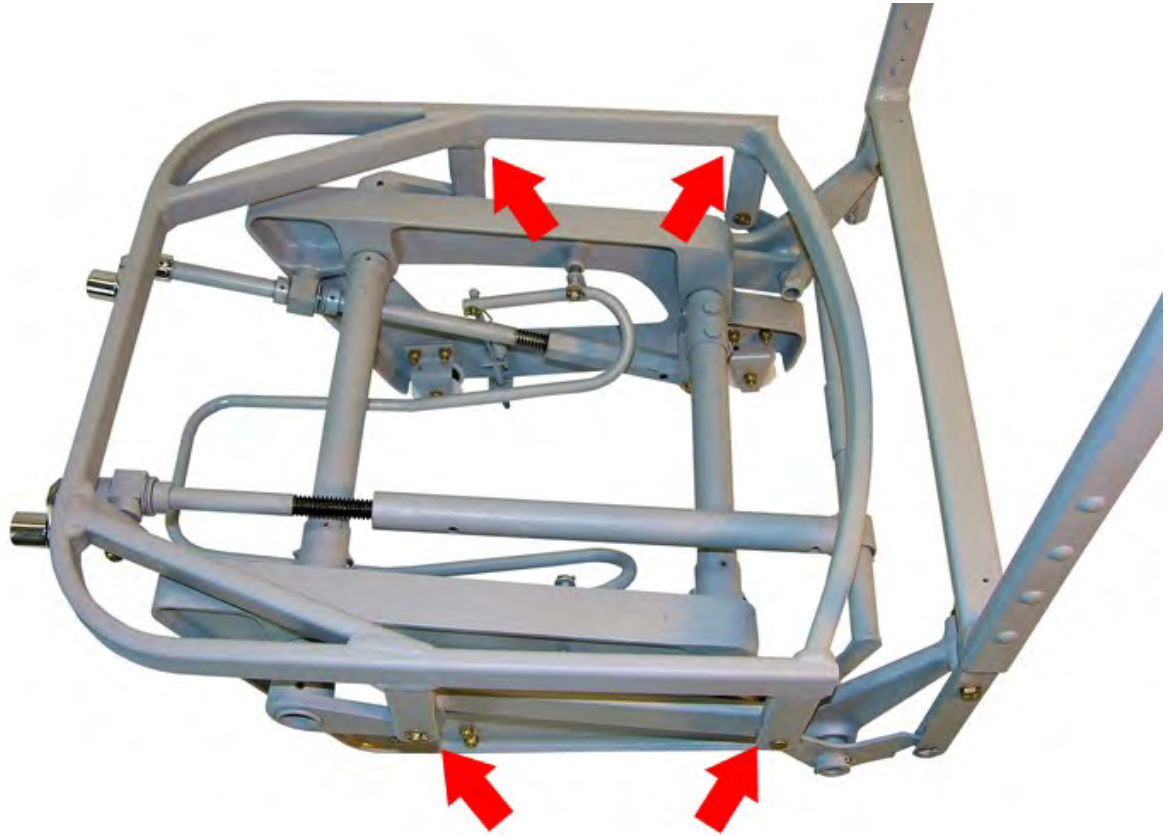

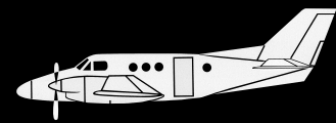

Cessna Seat Bottom Repair



Aircraft: Cessna (all series) 150, 152, 170, 172, 175, 177, 180, 182, 185, 205, 206, 207, 208, 210

Features: The OEM seat base mounting tabs ("legs") fatigue, bend, and in many cases break-off. The mounting pin holes also deform over time, not allowing the pins to remain tight, further stressing the mounting tabs. Our comprehensive repair begins with a thorough inspection, identification of worn and/or damaged parts, and then all needed repairs are performed.

Details: The AvFab repair actually upgrades the seat structure to "stronger than new". Many of the stress points of the seat frame are replaced with stronger material, during repair

Limitations: None

Installation: Re-installs the same as the original base

Approval: FAA 8130-3
EASA 8130-3 Dual Release

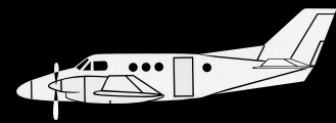

King Air Toilet Seat Frame Repair



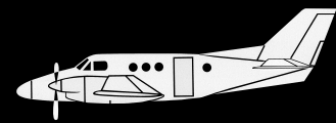

King Air Toilet Seat Frame Repair

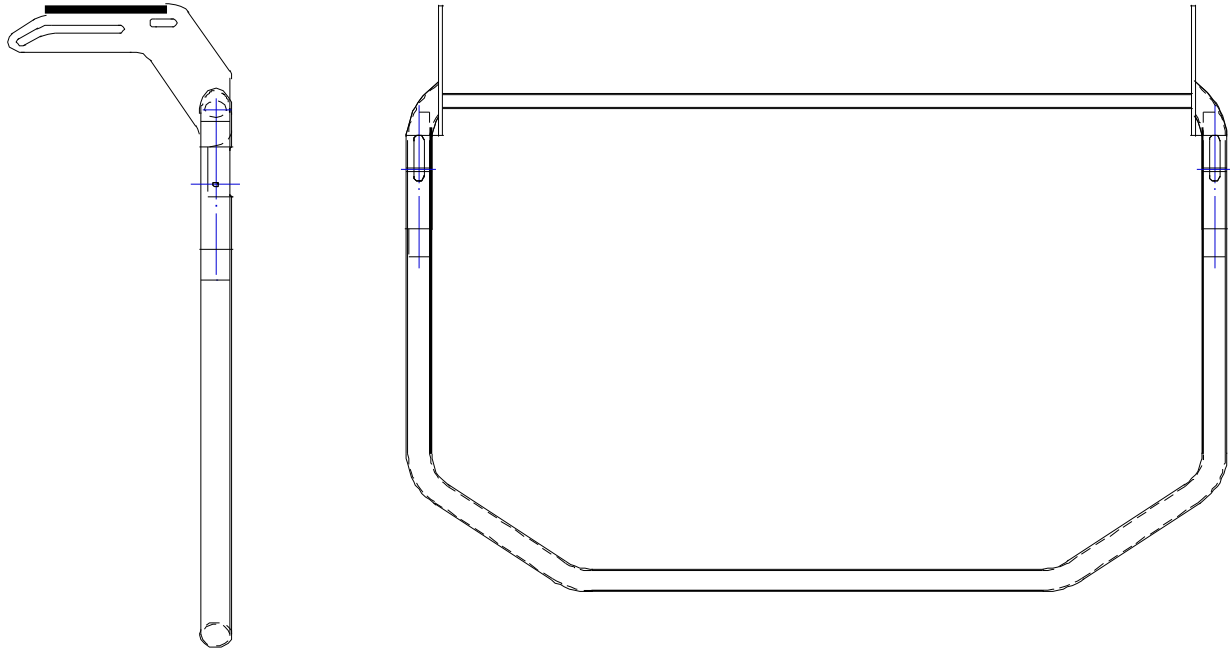

The OEM toilet frame tubing develops cracks and fatigues near the hinge brace. AvFab's FAA approved frame repair reinforces the frames to make them stronger than new.

Part Number: 101-531219-3 B200, 300, and early B300 (350) thru FL-289.
 130-530146-3 B300 (350) FL-290 thru FL-687 except
 FL-601 and FL-672.
 130-536009-0003 B300 (350) FL-601, FL-672, FL-688 and on.

Aircraft: Beechcraft B200, 300 and B300 (350)

Features: Frame reinforced as well as the damage repaired.

Options: Exchange units available.

Details: FAA approved repair reinforces the frames to make them stronger than new.

Approval: FAA 8130-3
 EASA 8130-3 Dual Release

Lead time: Quick turn time. Normally 5 days.

Warranty: One year.

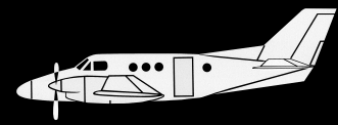

Beechjet & King Air Arm Rest Repair

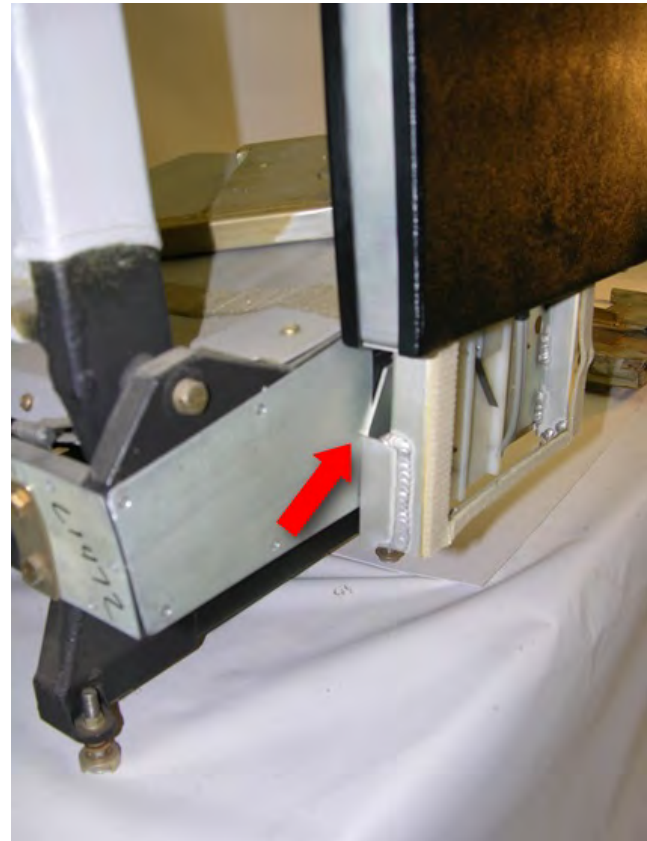
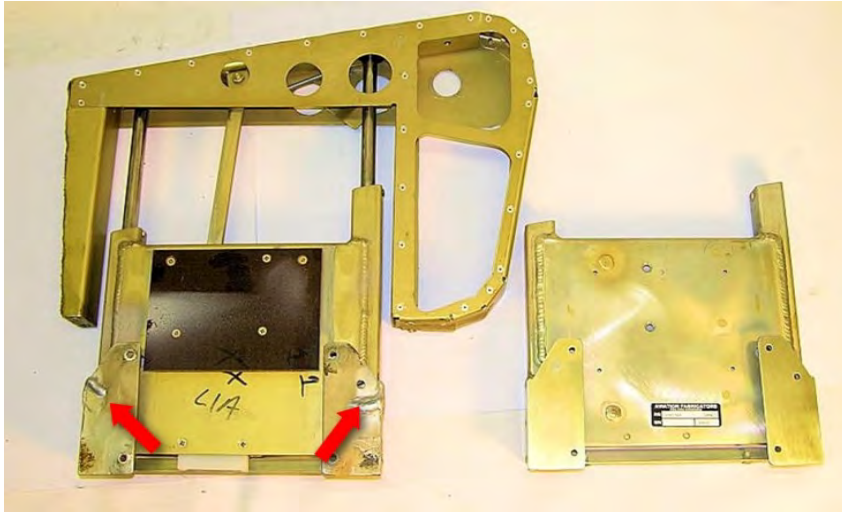

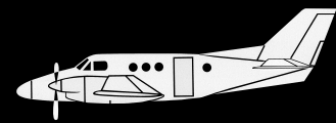

Beechjet & King Air Arm Rest Repair

King Air 350 (B300) and Hawker/Beechjet 400A with Tossington or Derlan OEM passenger seats have a chronic problem with their adjustable height armrest fatiguing and eventually failing. Passengers will sense that the armrest doesn't feel secure or leans toward the aisle. If not corrected, the bracket cracks and/or the guide rods will break and the arm will stop operating, or the armrest brackets will break and the armrest will come completely loose. Previously, the only option for operators has been to purchase an OEM replacement armrest as welding the cracks proves ineffective. We developed a CRS repair process that not only repairs the inherit design flaw, but prevents further reoccurrence by replacing the brackets with more robust ones and replacing the hollow OEM guide rods with solid ones.

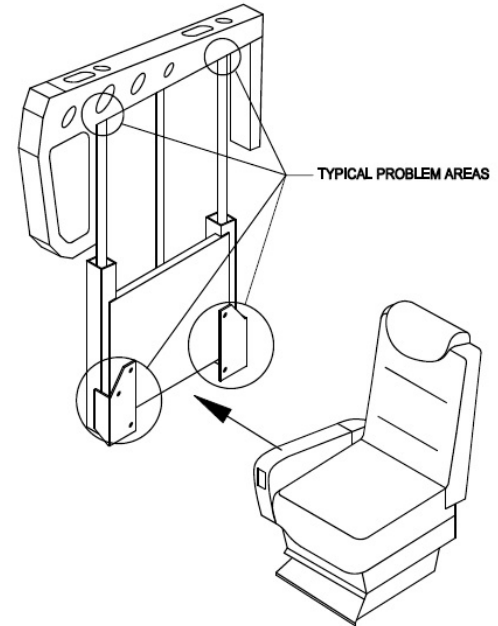

Part Number:	T1280 Series 1292-601 Armrest Assembly, 1292-602 Armrest Assembly
Aircraft:	Beechjet 400/400A Series King Air B300 (350) Series
Features:	The AvFab repair actually upgrades the armrest assembly to “stronger than new”. During the repair the stress points of the armrest are replaced with stronger material.
Options:	Exchange armrest may be available.
Details:	Comprehensive unit repair/modification will consist of adding stronger attaching brackets and slide tubes and detailed inspection of entire assembly.
Limitations:	None.
Installation:	Re-installs the same as the original armrest.
Approval:	FAA 8130-3 EASA 8130-3 Dual Release
Lead Time:	Normal lead time to make the repairs is 3 working days. Please contact us for an accurate estimate.
Warranty:	One year.

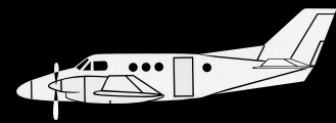

About Us

Over 25 years ago Aviation Fabricators (AvFab) opened for business in Clinton, Missouri to revolutionize the way Corporate and General Aviation interior parts are supported. Company founders G.R. Lowe and Jeff Lowe noticed their customers were requesting interior products that would enhance the value and versatility of their aircraft along with Certified Repairs that would return interior parts to service in a timely manner.

Central Airmotive:

These needs became evident during GR and Jeff's operation of Central Airmotive, the first company they founded together in 1980. Initially, obtaining F.A.A. Supplemental Type Certificate (STC) approved Side-Facing Divans were a focus, then pursuing additional product lines over the years including Jump Seats, High Density "Airline Style" seats, non-Medevac Stretcher Kits, and Cabin Table and Sidewall Kits, among others. Several STC's were acquired when AvFab bought San Antonio-based Custom Aircraft Conversions, while others were purchased from Branson Aircraft, Denver CO. AvFab now has well over 100 STC'd products which it ships globally, the majority of which were developed in-house.

Special Missions and ISR Aircraft Seating:

AvFab has recently turned considerable attention toward supporting Special Missions and ISR aircraft seating needs. These products include developing a Beechjet Operator's Seat for the US military T1A "Jayhawk". AvFab also supplies High-Density Seats, Observer Seats, and special missions Divans that are in place with domestic and foreign governments and military entities around the world.

The World's Largest Inventory of New and Used Interior Parts:

Sister company Central Airmotive supplies new and serviceable OEM interior parts, housing the world's largest inventory of new and used interior parts for single and multi-engine piston, turbine, and bizjet aircraft including every model of Beechcraft, most of the Cessna and Citation series, Hawker, Gulfstream, Falcon, Challenger, Learjet, and others in over 90,000 square feet of warehouses.

Concern For Safety is Evident in Everything AvFab Does...

Both G.R. Lowe and Jeff Lowe are licensed pilots, with GR possessing an ATP license with Seaplane endorsement, while Jeff holds a multi-engine instrument rating. G.R. is also a CFI with over 11,000 hours of experience. Their love for flying and concern for safety is evident in everything AvFab does..



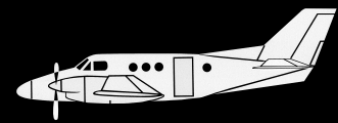

Learn more about AvFab's comprehensive line of products & services at:

www.AvFab.com

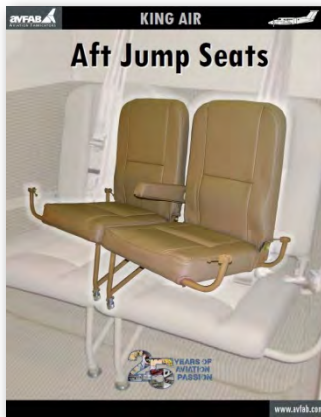

Aviation Fabricators

805 North 4th Street

Clinton, MO 64735

(660) 885-8317